

NOTES:

1. MATERIAL:
  - 1.1 HOUSING: THERMOPLASTIC, HIGH TEMP.,UL94V-0.
  - 1.2 CONTACT: COPPER ALLOY.
  - 1.3 FORK: COPPER ALLOY.
  - 1.4 NUT: COPPER ALLOY.
2. FINISH:
  - 2.1 CONTACT: GOLD FLASH PLATED ON CONTACT AND SOLDER TAIL AREA, NICKEL UNDERPLATING OVERALL.
  - 2.2 FORK: MATTE TIN PLATED OVERALL, NICKEL UNDERPLATING OVERALL.
  - 2.3 NUT: NICKEL UNDERPLATING OVERALL.
3. REFLOW SOLDER CAPABLE TO 260°C PER ACES SPEC.
4. SPEC.PLS REFER TO PS-54954-XXXXX-XXX
5. PACKAGE PLS REFER TO 54973-XXXXX-XX-TRP
6. PART NUMBER

54973-XXX X X-XXX

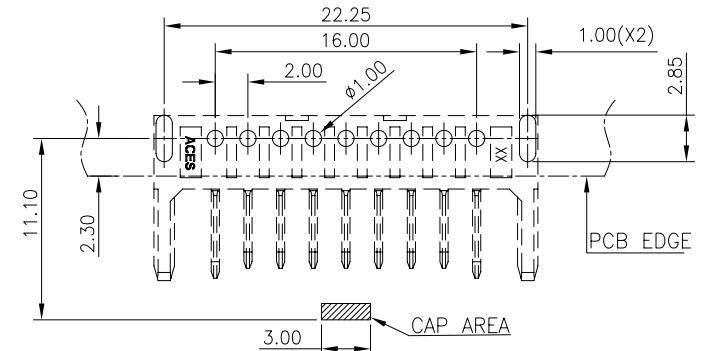
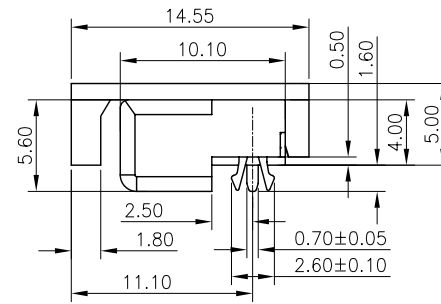
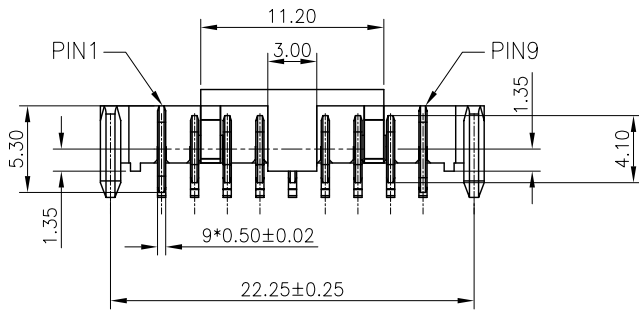
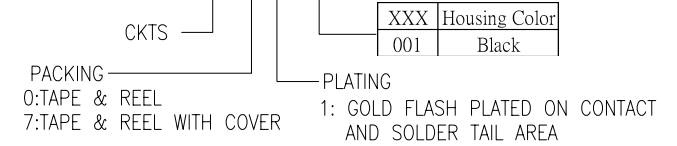

RECOMMENDED P.C.B. LAYOUT

TOLERANCE ±0.05 mm

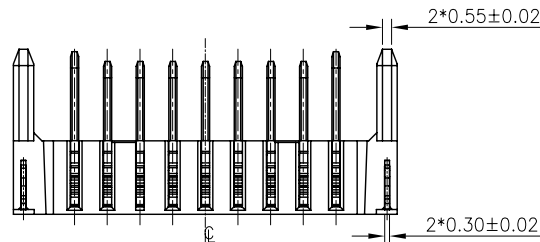

一般公差 <b>TOLERANCES</b> X ±0.5 XX ±0.15 X ±0.25 XXX ±0.1 ANGLES ±2°		<b>宏致電子股份有限公司</b> <b>Aces Electronics Co.,Ltd.</b>	
檢驗尺寸標示 <b>SYMBOLS</b> <b>INDICATE CLASSIFICATION DIMENSION</b>	品名 (TITLE) 2.00mm Battery Conn. Male DIP R/A Type H=4.0	製圖 (DR) 16'/06/02 SKY	審核 (CHKD) BRAVE
MARK IS CRITICAL DIM. MARK IS MAJOR DIM.	圖號 (DWG NO.) 54973-XXXXX-XXX	核准 (APPD) FRANK	
表面處理 (FINISH)	比例 (SCALE) 4:1	單位 (UNITS) mm	張數 (SHEET) 1 OF 1
			SIZE A4
			REV 0